

TS-XFBL-332710-40D

10Gb/s BIDI XFP Transceiver

PRODUCT FEATURES

- Hot-pluggable XFP footprint
- Supports 9.95Gb/s to 11.3Gb/s bit rates
- XFI Loopback Mode
- RoHS-6 Compliant (lead-free)
- Power dissipation<2W
- Case operating temperature:-5 °C~70°C
- Single Mode LC Receptacle Bi-directional Transceiver
- Up to 40km transmission on SMF
- 1330nm DFB laser and PIN receiver
- 2-wire interface with integrated Digital Diagnostic monitoring
- EEPROM with Serial ID Functionality
- Compliant with XFP MSA with duplex LC connector



APPLICATIONS

- 10GBASE-BX 10.3125Gb/s Ethernet
- 10GBASE-BX 9.953Gb/s Ethernet
- SONET OC-192 SR-1 SDH STM I-64.1

PRODUCT DESCRIPTION

TS-XFBL-332710-40D is hot pluggable 3.3V Small-Form-Factor transceiver module. It designed expressly for high-speed communication applications that require rates up to 11.3Gb/s, it designed to be compliant with XFP MSA. The module data link up to 40km in 9/125um single mode fiber. The optical output can be disabled by a LVTTTL logic high-level input of Tx Disable. Tx Fault is provided to indicate that degradation of the laser. Loss of signal (LOS) output is provided to indicate the loss of an input optical signal of receiver or the link status with partner.

I . Absolute Maximum Ratings

Parameter	Symbol	Min.	Typ.	Max.	Unit	Note
Storage Temperature	Ts	-40	-	85	°C	
Storage Ambient Humidity	HA	5	-	95	%	
Operating Relative Humidity	RH	-	-	85	%	
Power Supply Voltage	VCC	-0.3	-	4	V	
Signal Input Voltage	VCC	Vcc-0.3	-	Vcc+0.3	V	

II . Recommended Operating Conditions

Parameter	Symbol	Min.	Typ.	Max.	Unit	Note
Case Operating Temperature	Tcase	-5	-	70	°C	Without air flow
Power Supply Voltage	VCC	3.14	3.3	3.47	V	
Power Supply Current	ICC	-	-	450	mA	
Data Rate	BR	9.95	10.3125	11.3	Gbps	
Transmission Distance	TD		-	40	km	Note (1)
Coupled fiber	Single mode fiber					

Note: Measured with SMF

III. Optical Characteristics

Parameter	Symbol	Min.	Typ.	Max.	Unit	Note
Transmitter						
Average Launched Power	PO	0	-	4	dBm	
Average Launched Power(Laser Off)	POUT-OFF	-	-	-30	dBm	Note (1)
Centre Wavelength Range	λ_C	1320	1330	1340	nm	
Side mode suppression ratio	SMSR	30	-	-	dB	
Spectrum Bandwidth(-20dB)	σ	-	-	1	nm	
Extinction Ratio	ER	3.5	6	-	dB	Note (2)
Output Eye Mask	Compliant with IEEE 802.3 ae					Note (2)
Receiver						
Input Optical Wavelength	λ_{IN}	1260	1270	1280	nm	

Receiver Sensitivity in average	PIN	-	-	-15	dBm	Note (3)
Input Saturation Power (Overload)	PSAT	0.5	-	-	dBm	Note (3)
LOS -Assert Power	PA	-30	-	-	dBm	
LOS -Deassert Power	PD	-	-	-18	dBm	
LOS -Hysteresis	PHys	0.5	-	4	dB	

Note:

1. The optical power is launched into SMF
2. Measured with RPBS 2³¹-1 test pattern @10.3125Gbs
3. Measured with RPBS 2³¹-1 test pattern @10.3125Gbs BER=<10⁻¹² ER=6dB

IV. Electrical Interface Characteristics

Parameter	Symbol	Min.	Typ.	Max.	Unit	Note
Total power supply current	Icc	-	-	350	mA	
Transmitter						
Differential Data Input Voltage	VDT	120	-	820	mVp-p	
Differential line input Impedance	RIN	85	100	115	Ohm	
Transmitter Fault Output-High	VFaultH	2.4	-	Vcc	V	
Transmitter Fault Output-Low	VFaultL	-0.3	-	0.8	V	
Transmitter Disable Voltage- High	VDisH	2	-	Vcc+0.3	V	
Transmitter Disable Voltage- low	VDisL	-0.3	-	0.8	V	
Receiver						
Differential Data Output Voltage	VDR	300	-	850	mVp-p	
Differential line Output Impedance	ROUT	80	100	120	Ohm	
Receiver LOS Pull up Resistor	RLOS	4.7	-	10	KOhm	
Data Output Rise/Fall time	tr/tf	20	-	-	ps	
LOS Output Voltage-High	VLOSH	2	-	Vcc	V	
LOS Output Voltage-Low	VLOSL	-0.3	-	0.4	V	

V. Pin Assignment

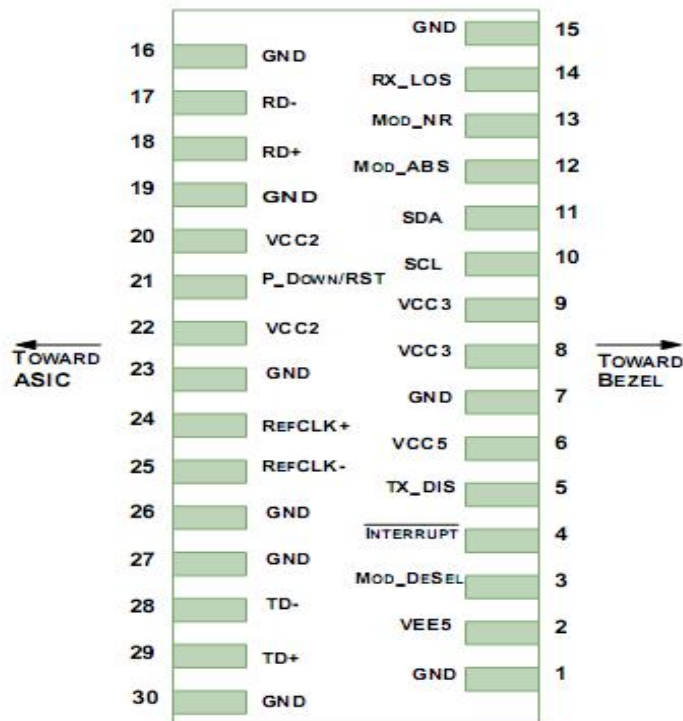

Diagram of Host Board Connector Block Pin Numbers and Name

Pin	Logic	Symbol	Name/Description	Note
1		GND	Module Ground	1
2		VEE5	Optional -5.2 Power Supply – Not required	
3	LVTTL-I	Mod-Desel	Module De-select; When held low allows the module to respond to 2-wire serial interface commands	
4	LVTTL-O	Interrupt	Interrupt (bar); Indicates presence of an important condition which can be read over the serial 2-wire interface	2
5	LVTTL-I	TX_DIS	Transmitter Disable; Transmitter laser source turned off	
6		VCC5	+5 Power Supply	
7		GND	Module Ground	1
8		VCC3	+3.3V Power Supply	
9		VCC3	+3.3V Power Supply	
10	LVTTL-I	SCL	Serial 2-wire interface clock	2
11	LVTTLI/O	SDA	Serial 2-wire interface data line	2
12	LVTTL-O	Mod_Abs	Module Absent; Indicates module is not present. Grounded in the module.	2
13	LVTTL-O	Mod_NR	Module Not Ready; TRANSCOM defines it as a logical OR between RX_LOS and Loss of Lock in TX/RX.	2
14	LVTTL-O	RX_LOS	Receiver Loss of Signal indicator	2
15		GND	Module Ground	1
16		GND	Module Ground	1
17	CML-O	RD-	Receiver inverted data output	
18	CML-O	RD+	Receiver non-inverted data output	
19		GND	Module Ground	1
20		VCC2	+1.8V Power Supply – Not required	

21	LVTTTL-I	P_Down/RST	Power Down; When high, places the module in the low power stand-by mode and on the falling edge of P_Down initiates a module reset	
			Reset; The falling edge initiates a complete reset of the module including the 2-wire serial interface, equivalent to a power cycle.	
22		VCC2	+1.8V Power Supply – Not required	
23		GND	Module Ground	1
24	PECL-I	RefCLK+	Reference Clock non-inverted input, AC coupled on the host board – Not required	3
25	PECL-I	RefCLK-	Reference Clock inverted input, AC coupled on the host board – Not required	3
26		GND	Module Ground	1
27		GND	Module Ground	1
28	CML-I	TD-	Transmitter inverted data input	
29	CML-I	TD+	Transmitter non-inverted data input	
30		GND	Module Ground	1

Notes:

1. Module circuit ground is isolated from module chassis ground within the module.
2. Open collector; should be pulled up with 4.7k – 10kohms on host board to a voltage between 3.15V and 3.6V.
3. A Reference Clock input is not required by the TS-XFBL-332710-40D. If present, it will be ignored.

VI. Recommended Block Circuit

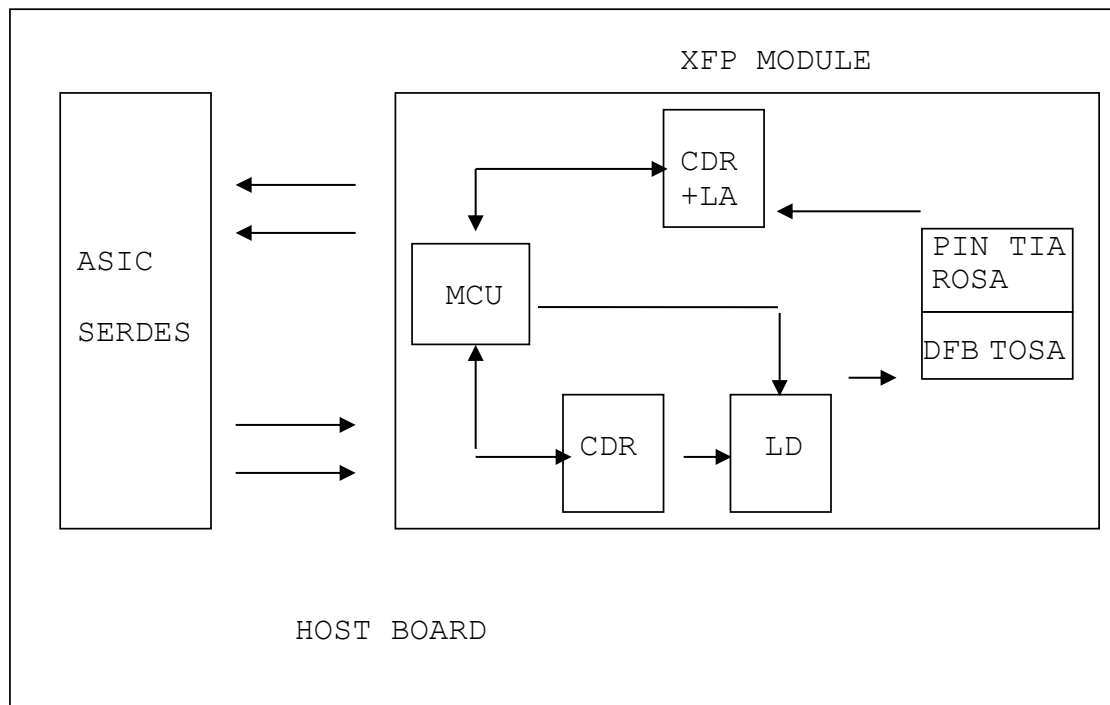

VII. Outline Dimensions

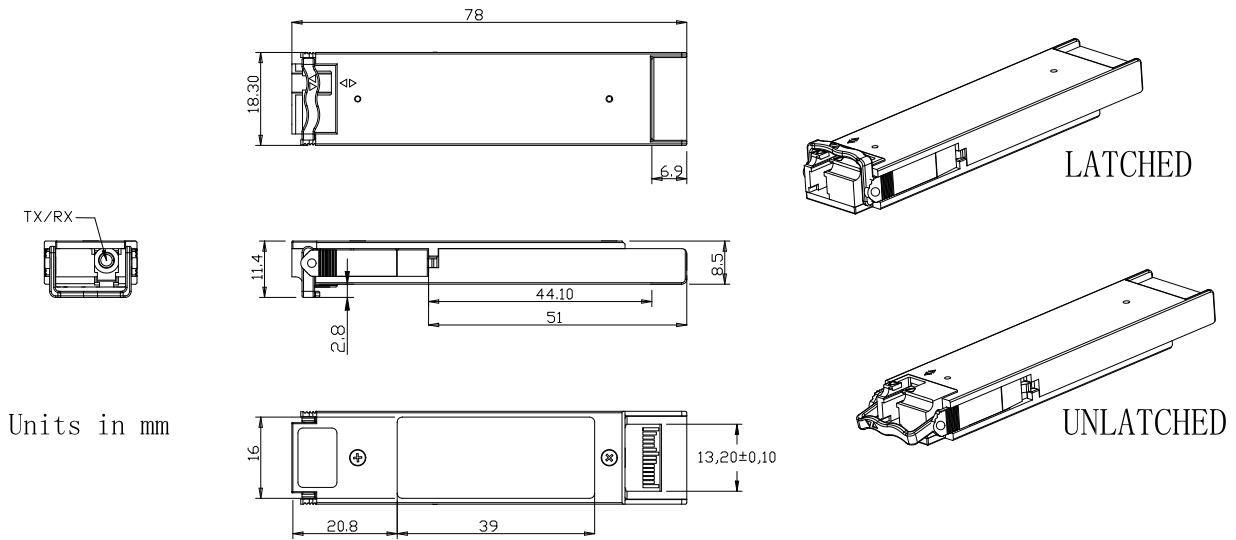

VIII. Regulatory Compliance

Feature	Reference	Performance
Electrostatic discharge (ESD)	IEC/EN 61000-4-2	Compatible with standards
Electromagnetic Interference (EMI)	FCC Part 15 Class B EN 55022 Class B (CISPR 22A)	Compatible with standards
Laser Eye Safety	FDA 21CFR 1040.10, 1040.11 IEC/EN 60825-1, 2	Class 1 laser product
Component Recognition	IEC/EN 60950 , UL	Compatible with standards
ROHS	2002/95/EC	Compatible with standards
EMC	EN61000-3	Compatible with standards

Appendix A. Document Revision

Version No.	Date	Description
1.0	2010-09-01	Preliminary datasheet
2.0	2011-09-10	Update format and company's logo